

Series ONS

SET-3

कोड नं. **55/3/N**
Code No.

रोल नं.
Roll No.

परीक्षार्थी कोड को उत्तर-पुस्तिका के मुख-पृष्ठ पर अवश्य लिखें।

Candidates must write the Code on the title page of the answer-book.

- कृपया जाँच कर लें कि इस प्रश्न-पत्र में मुद्रित पृष्ठ **16** हैं।
- प्रश्न-पत्र में दाहिने हाथ की ओर दिए गए कोड नम्बर को छात्र उत्तर-पुस्तिका के मुख-पृष्ठ पर लिखें।
- कृपया जाँच कर लें कि इस प्रश्न-पत्र में **26** प्रश्न हैं।
- कृपया प्रश्न का उत्तर लिखना शुरू करने से पहले, प्रश्न का क्रमांक अवश्य लिखें।
- इस प्रश्न-पत्र को पढ़ने के लिए 15 मिनट का समय दिया गया है। प्रश्न-पत्र का वितरण पूर्वाह्न में 10.15 बजे किया जाएगा। 10.15 बजे से 10.30 बजे तक छात्र केवल प्रश्न-पत्र को पढ़ेंगे और इस अवधि के दौरान वे उत्तर-पुस्तिका पर कोई उत्तर नहीं लिखेंगे।
- Please check that this question paper contains **16** printed pages.
- Code number given on the right hand side of the question paper should be written on the title page of the answer-book by the candidate.
- Please check that this question paper contains **26** questions.
- **Please write down the Serial Number of the question before attempting it.**
- 15 minute time has been allotted to read this question paper. The question paper will be distributed at 10.15 a.m. From 10.15 a.m. to 10.30 a.m., the students will read the question paper only and will not write any answer on the answer-book during this period.

भौतिक विज्ञान (सैद्धांतिक)

PHYSICS (Theory)

निर्धारित समय : 3 घण्टे

अधिकतम अंक : 70

Time allowed : 3 hours

Maximum Marks : 70

55/3/N

1

P.T.O.



सामान्य निर्देश :

- (i) सभी प्रश्न अनिवार्य हैं। इस प्रश्न-पत्र में कुल 26 प्रश्न हैं।
- (ii) इस प्रश्न-पत्र के 5 भाग हैं : खण्ड अ, खण्ड ब, खण्ड स, खण्ड द और खण्ड य।
- (iii) खण्ड अ में 5 प्रश्न हैं, प्रत्येक का 1 अंक है। खण्ड ब में 5 प्रश्न हैं, प्रत्येक के 2 अंक हैं। खण्ड स में 12 प्रश्न हैं, प्रत्येक के 3 अंक हैं। खण्ड द में 4 अंक का एक मूल्याधारित प्रश्न है और खण्ड य में 3 प्रश्न हैं, प्रत्येक के 5 अंक हैं।
- (iv) प्रश्न-पत्र में समग्र पर कोई विकल्प नहीं है। तथापि, दो अंकों वाले एक प्रश्न में, तीन अंकों वाले एक प्रश्न में और पाँच अंकों वाले तीनों प्रश्नों में आन्तरिक चयन प्रदान किया गया है। ऐसे प्रश्नों में आपको दिए गए चयन में से केवल एक प्रश्न ही करना है।
- (v) जहाँ आवश्यक हो आप निम्नलिखित भौतिक नियतांकों के मानों का उपयोग कर सकते हैं :

$$c = 3 \times 10^8 \text{ m/s}$$

$$h = 6.63 \times 10^{-34} \text{ Js}$$

$$e = 1.6 \times 10^{-19} \text{ C}$$

$$\mu_0 = 4\pi \times 10^{-7} \text{ T m A}^{-1}$$

$$\epsilon_0 = 8.854 \times 10^{-12} \text{ C}^2 \text{ N}^{-1} \text{ m}^{-2}$$

$$\frac{1}{4\pi\epsilon_0} = 9 \times 10^9 \text{ N m}^2 \text{ C}^{-2}$$

$$\text{इलेक्ट्रॉन का द्रव्यमान} = 9.1 \times 10^{-31} \text{ kg}$$

$$\text{न्यूट्रॉन का द्रव्यमान} = 1.675 \times 10^{-27} \text{ kg}$$

$$\text{प्रोटॉन का द्रव्यमान} = 1.673 \times 10^{-27} \text{ kg}$$

$$\text{आवोगाद्रो संख्या} = 6.023 \times 10^{23} \text{ प्रति ग्राम मोल}$$

$$\text{बोल्ट्जमान नियतांक} = 1.38 \times 10^{-23} \text{ JK}^{-1}$$

General Instructions :

- (i) *All questions are **compulsory**. There are **26** questions in all.*
- (ii) *This question paper has **five** sections : Section A, Section B, Section C, Section D and Section E.*
- (iii) *Section A contains **five** questions of **one** mark each, Section B contains **five** questions of **two** marks each, Section C contains **twelve** questions of **three** marks each, Section D contains **one** value based question of **four** marks and Section E contains **three** questions of **five** marks each.*
- (iv) *There is no overall choice. However, an internal choice has been provided in **one** question of **two** marks, **one** question of **three** marks and all the **three** questions of **five** marks weightage. You have to attempt only **one** of the choices in such questions.*
- (v) *You may use the following values of physical constants wherever necessary.*

$$c = 3 \times 10^8 \text{ m/s}$$

$$h = 6.63 \times 10^{-34} \text{ Js}$$

$$e = 1.6 \times 10^{-19} \text{ C}$$

$$\mu_0 = 4\pi \times 10^{-7} \text{ T m A}^{-1}$$

$$\epsilon_0 = 8.854 \times 10^{-12} \text{ C}^2 \text{ N}^{-1} \text{ m}^{-2}$$

$$\frac{1}{4\pi\epsilon_0} = 9 \times 10^9 \text{ N m}^2 \text{ C}^{-2}$$

$$\text{Mass of electron} = 9.1 \times 10^{-31} \text{ kg}$$

$$\text{Mass of neutron} = 1.675 \times 10^{-27} \text{ kg}$$

$$\text{Mass of proton} = 1.673 \times 10^{-27} \text{ kg}$$

$$\text{Avogadro's number} = 6.023 \times 10^{23} \text{ per gram mole}$$

$$\text{Boltzmann constant} = 1.38 \times 10^{-23} \text{ JK}^{-1}$$

खण्ड - अ

SECTION - A

1. 2 MHz आवृत्ति की किसी वाहक तरंग पर कोई 5 kHz आवृत्ति का सिग्नल आयाम मॉडुलित है। उत्पन्न पार्श्व बैंडों की आवृत्तियाँ क्या हैं? 1

A signal of 5 kHz frequency is amplitude modulated on a carrier wave of frequency 2 MHz. What are the frequencies of the side bands produced ?

2. आवेशित कण की कुण्डलिनी गति का क्या कारण हो सकता है? 1

What can be the cause of helical motion of a charged particle ?

3. किसी आवेश वाहक की गतिशीलता की परिभाषा लिखिए। इसका विश्रांति काल से क्या संबंध है? 1

Define mobility of a charge carrier. What is its relation with relaxation time ?

4. त्रिज्या 'r' के किसी चाप, जिसके केन्द्र पर कोई अन्य आवेश 'q' स्थित है, के चारों ओर किसी आवेश Q को गति कराने में कितना कार्य किया जाता है? 1

What is the amount of work done in moving a point charge Q around a circular arc of radius 'r' at the centre of which another point charge 'q' is located ?

5. कुहरे से होकर हम स्पष्ट क्यों नहीं देख पाते? इसके लिए उत्तरदायी परिघटना का नाम लिखिए। 1

Why can't we see clearly through fog ? Name the phenomenon responsible for it.

खण्ड - ब

SECTION - B

6. हाइड्रोजन परमाणु के उत्सर्जन स्पेक्ट्रम में H_{α} -रेखाएं कब प्राप्त होती हैं? इस संक्रमण में उत्सर्जित फोटॉन की आवृत्ति परिकलित कीजिए। 2

अथवा

हाइड्रोजन परमाणु में जब इलेक्ट्रॉन $n = \infty$ से $n = 1$ पर कूदान करता है, तब उत्सर्जित विकिरणों की तरंगदैर्घ्य परिकलित कीजिए।

When is H_{α} line in the emission spectrum of hydrogen atom obtained? Calculate the frequency of the photon emitted during this transition. 2

OR

Calculate the wavelength of radiation emitted when electron in a hydrogen atom jumps from $n = \infty$ to $n = 1$.

7. जब किसी 0.1 m लम्बे तार के सिरों पर 5V विभवान्तर लगाया जाता है, तो इलेक्ट्रॉनों की अपवाह चाल 2.5×10^{-4} m/s होती है। यदि तार में इलेक्ट्रॉन घनत्व 8×10^{28} m^{-3} है, तो तार के पदार्थ की प्रतिरोधकता परिकलित कीजिए। 2

When 5V potential difference is applied across a wire of length 0.1 m, the drift speed of electrons is 2.5×10^{-4} m/s. If the electron density in the wire is 8×10^{28} m^{-3} , calculate the resistivity of the material of wire.

8. किसी प्रोटॉन तथा α -कण को समान विभवान्तर से त्वरित किया गया है। इनमें से किसकी (i) दे ब्रॉग्ली तरंगदैर्घ्य अधिक, और (ii) गतिज ऊर्जा कम है? अपने उत्तर की पुष्टि कीजिए। 2

A proton and an α particle are accelerated through the same potential difference. Which one of the two has (i) greater de-Broglie wavelength, and (ii) less kinetic energy? Justify your answer.

9. आरेख में दर्शाए अनुसार कोई किरण PQ प्रिज़्म BAC के अपवर्ती फलक BA पर आपतित होकर इसके अन्य अपवर्ती फलक AC से RS के रूप में इस प्रकार निर्गत होती है, कि $AQ = AR$ हो। यदि प्रिज़्म कोण $A = 60^\circ$ तथा प्रिज़्म के पदार्थ का अपवर्तनांक $\sqrt{3}$ है, तो कोण θ परिकलित कीजिए। 2

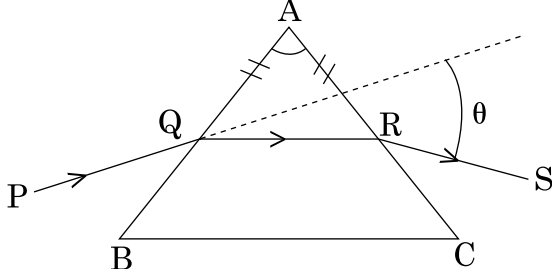

A ray PQ incident on the refracting face BA is refracted in the prism BAC as shown in the figure and emerges from the other refracting face AC as RS such that $AQ = AR$. If the angle of prism $A = 60^\circ$ and refractive index of material of prism is $\sqrt{3}$, calculate angle θ .

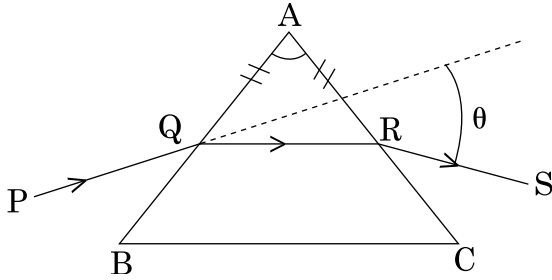

10. आधार बैंड सिग्नल को सीधे ही प्रेषित क्यों नहीं किया जाता? कोई दो कारण लिखिए। 2
Why is base band signal not transmitted directly? Give any two reasons.

खण्ड - स
SECTION - C

11. (i) कोई पर्दा किसी बिम्ब से 100 cm दूरी पर स्थित है। इस पर्दे पर किसी उत्तल लेंस की दो स्थितियों, जिनके बीच की दूरी 20 cm है, के लिए प्रतिबिम्ब बनते हैं। लेंस की फोकस दूरी परिकलित कीजिए। 3
- (ii) कोई अभिसारी लेंस किसी अपसारी लेंस के समाक्ष सम्पर्क में रखा है तथा दोनों लेंसों की फोकस दूरियां समान हैं। इस संयोजन का फोकस दूरी क्या है?

- (i) A screen is placed at a distance of 100 cm from an object. The image of the object is formed on the screen by a convex lens for two different locations of the lens separated by 20 cm. Calculate the focal length of the lens used.
- (ii) A converging lens is kept coaxially in contact with a diverging lens - both the lenses being of equal focal length. What is the focal length of the combination ?

12. (a) किसी रेडियोएक्टिव नाभिक के नमूने के रेडियोएक्टिव क्षय की दर के नियम के लिए गणितीय व्यंजक व्युत्पन्न कीजिए। 3

(b) किसी दिए गए रेडियोएक्टिव नाभिक की औसत आयु उसके क्षय-स्थिरांक (विघटन-स्थिरांक) से किस प्रकार संबंधित है ?

(a) Derive the mathematical expression for law of radioactive decay for a sample of a radioactive nucleus.

(b) How is the mean life of a given radioactive nucleus related to the decay constant ?

13. आकाश तरंगों द्वारा प्रसारण क्या है? उन कारकों का उल्लेख कीजिए जो इनके प्रसारण के परिसर को सीमित करते हैं। आकाश तरंगों द्वारा प्रसारण के लिए दो एन्टेनाओं के बीच की अधिकतम दृष्टि रेखीय दूरी के लिए व्यंजक प्राप्त कीजिए। 3

What is space wave propagation ? State the factors which limit its range of propagation. Derive an expression for the maximum line of sight distance between two antennas for space wave propagation.



14. (i) ऊर्जा बैंड आरेख के आधार पर किसी चालक और अर्धचालक के बीच विभेदन कीजिए। 3
- (ii) नीचे दिए गए आरेख में किसी गेट के निवेशी तरंग रूप (A, B) तथा निर्गत तरंग रूप (Y) दर्शाए गए हैं। इस गेट को पहचानिए, इसकी सत्यमान सारणी लिखिए और तर्क प्रतीक खींचिए।

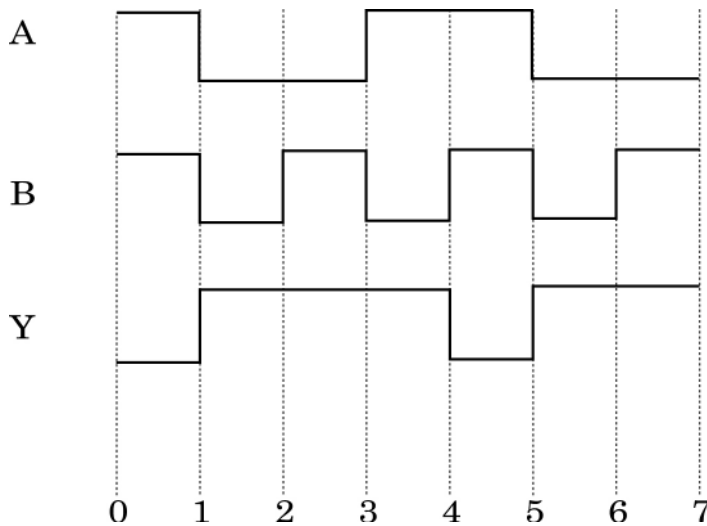

- (i) Distinguish between a conductor and a semi conductor on the basis of energy band diagram.
- (ii) The following figure shows the input waveforms (A, B) and the output waveform (Y) of a gate. Identify the gate, write its truth table and draw its logic symbol.

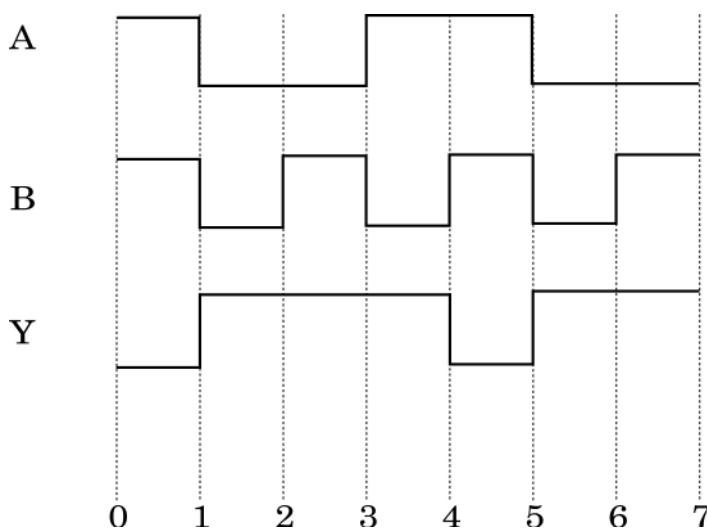

15. (i) उन दो महत्वपूर्ण प्रक्रियाओं का नाम लिखिए जो pn संधि बनते समय होती हैं। 3
(ii) पूर्ण तरंग दिष्टकारी का विद्युत् परिपथ निवेशी और निर्गत तरंग रूपों सहित खींचिए। संक्षेप में व्याख्या कीजिए कि निर्गत वोल्टता/धारा किस प्रकार एक दिशिक होती है।
(i) Name two important processes that occur during the formation of a pn junction.
(ii) Draw the circuit diagram of a full wave rectifier along with the input and output waveforms. Briefly explain how the output voltage/current is unidirectional.
16. आइंस्टीन की प्रकाश-विद्युत् समीकरण लिखने में उपयोग होने वाले फोटॉनों के दो महत्वपूर्ण गुणों का उल्लेख कीजिए। आइंस्टीन की समीकरण का उपयोग करके तथा प्रासंगिक राशियों के बीच आवश्यक ग्राफ खींचकर (i) निरोधी विभव, और (ii) देहली आवृत्ति की परिभाषा लिखिए। 3
State two important properties of photon which are used to write Einstein's photoelectric equation. Define (i) stopping potential and (ii) threshold frequency, using Einstein's equation and drawing necessary plot between relevant quantities.
17. (i) प्रकाश के सघन माध्यम से विरल माध्यम में गमन करने के प्रकरण में हाइगेन्स के तरंग सिद्धान्त के आधार पर स्नेल का नियम व्युत्पन्न कीजिए। 3
(ii) समतल तरंगाग्र और गोलीय तरंगाग्र के बीच विभेदन करने के लिए आरेख खींचिए।
(i) Derive Snell's law on the basis of Huygen's wave theory when light is travelling from a denser to a rarer medium.
(ii) Draw the sketches to differentiate between plane wavefront and spherical wavefront.
18. विद्युत् चुम्बकीय तरंगें किस प्रकार उत्पन्न होती हैं? इन तरंगों की ऊर्जा का स्रोत क्या होता है? 3
z-अक्ष के अनुदिश संचरण करने वाली किसी विद्युत्-चुम्बकीय तरंग के विद्युत् एवं चुम्बकीय क्षेत्रों के लिए गणितीय व्यंजन लिखिए। विद्युत् चुम्बकीय तरंगों के कोई दो गुण लिखिए।
How are electromagnetic waves produced? What is the source of energy of these waves? Write mathematical expressions for electric and magnetic fields of an electromagnetic wave propagating along the z-axis. Write any two important properties of electromagnetic waves.



19. (i) जब किसी AC स्रोत को किसी आदर्श संधारित्र से संयोजित किया जाता, तो यह दर्शाइए कि एक पूरे चक्र में स्रोत द्वारा आपूर्त औसत शक्ति शून्य होती है। 3
- (ii) कोई बल्ब किसी परिवर्ती संधारित्र से A.C. स्रोत से श्रेणी क्रम में संयोजित है। इस बल्ब की चमक को क्या होता है जब परिपथ में प्लग लगा दिया जाता है और संधारित्र की धारिता को धीरे-धीरे घटाया जाता है?

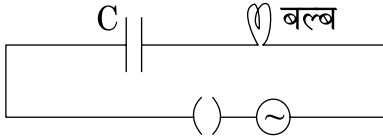

- (i) When an AC source is connected to an ideal capacitor, show that the average power supplied by the source over a complete cycle is zero.
- (ii) A bulb is connected in series with a variable capacitor and an A.C. source as shown. What happens to the brightness of the bulb when the key is plugged in and capacitance of the capacitor is gradually reduced ?

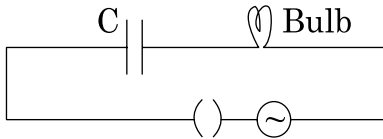

20. एम्पियर का परिपथीय नियम लिखिए। इस नियम का उपयोग करके सीधे अनन्त विद्युत् वाही चालक का चुम्बकीय क्षेत्र ज्ञात कीजिए। चुम्बकीय क्षेत्र रेखाएँ स्थिर विद्युत् क्षेत्र रेखाओं से किस प्रकार भिन्न होती हैं? 3

अथवा

साइक्लोट्रॉन का सिद्धान्त लिखिए। यह दर्शाइए कि साइक्लोट्रॉन में कणों का परिक्रमण-काल उनकी चालों पर निर्भर नहीं करता। साइक्लोट्रॉन के प्रचालन के लिए यह गुण आवश्यक क्यों है?

State Ampere's circuital law. Use this law to find magnetic field due to straight infinite current carrying wire. How are the magnetic field lines different from the electrostatic field lines ?

OR

State the principle of a cyclotron. Show that the time period of revolution of particles in a cyclotron is independent of their speeds. Why is this property necessary for the operation of a cyclotron ?

21. 1.5 V emf के दो सर्वसम सेलों को पार्श्व में संयोजित करके पार्श्व में संयोजित 7Ω के दो प्रतिरोधकों के बाह्य परिपथ को विद्युत् की आपूर्ति की गयी है। अति उच्च प्रतिरोध के किसी वोल्टमीटर से इन सेलों की टर्मिनल वोल्टता 1.4 V मापी जाती है। प्रत्येक सेल का आन्तरिक प्रतिरोध परिकल्पित कीजिए। 3

Two identical cells of emf 1.5 V each joined in parallel supply energy to an external circuit consisting of two resistances of 7Ω each joined in parallel. A very high resistance voltmeter reads the terminal voltage of cells to be 1.4 V. Calculate the internal resistance of each cell.

22. किसी एकसमान आवेशित गोलीय खोल के कारण (i) खोल के बाहर तथा (ii) खोल के भीतर किसी बिन्दु पर विद्युत् क्षेत्र तीव्रता ज्ञात कीजिए। खोल के केन्द्र से दूरी और विद्युत् क्षेत्र के बीच ग्राफ खींचिए। 3

Find the electric field intensity due to a uniformly charged spherical shell at a point (i) outside the shell and (ii) inside the shell. Plot the graph of electric field with distance from the centre of the shell.

खण्ड - द

SECTION - D

23. सीमा के चाचा जी को डॉक्टर ने मस्तिष्क का MRI (चुम्बकीय अनुनाद चित्रण) क्रमवीक्षण कराने का परामर्श दिया। उसके चाचा जी को यह मंहगा लगा और वे इसे स्थगित करना चाहते थे। 4

जब सीमा को यह ज्ञात हुआ, तो उसने अपने परिवार से सहायता ली और डॉक्टर से सम्पर्क भी किया तथा उन्होंने भी इलाज के खर्च में भारी छूट देने का आश्वासन दिया। इसके पश्चात् सीमा ने अपने चाचा जी को इस परीक्षण के लिए मना लिया, ताकि उनके मस्तिष्क की स्थिति के बारे में ज्ञात हो सके। परीक्षण से प्राप्त जानकारी ने डॉक्टर को उचित इलाज करने में अत्यधिक सहायता दी।

उपरोक्त गद्यांश के आधार पर नीचे दिए गए प्रश्नों के उत्तर दीजिए :

- (a) आपके विचार से सीमा, उसके परिवार तथा डॉक्टर द्वारा किन मूल्यों को दर्शाया गया है?
- (b) MRI परीक्षण के अत्यधिक महंगे होने का क्या सम्भावित कारण हो सकता है?
- (c) यह मानते हुए कि MRI परीक्षण 0.1 T के चुम्बकीय क्षेत्र का उपयोग करके किया गया, तो उस प्रोटॉन (आवेश = 1.6×10^{-19} C) पर, जो 10^4 m/s की चाल से गतिमान था, चुम्बकीय क्षेत्र द्वारा आरोपित बल का निम्नतम और अधिकतम मान ज्ञात कीजिए।



Seema's uncle was advised by his doctor to have an MRI (Magnetic Resonance Imaging) scan of his brain. Her uncle felt it to be expensive and wanted to postpone it.

When Seema learnt about this, she took the help of her family and also approached the doctor, who also offered a substantial discount. She then convinced her uncle to undergo the test to enable the doctor to know the condition of his brain. The information thus obtained greatly helped the doctor to treat him properly.

Based on the above paragraph, answer the following questions :

- What according to you are the values displayed by Seema, her family and the doctor ?
- What could be the possible reason for MRI test to be so expensive ?
- Assuming that MRI test was performed using a magnetic field of 0.1 T., find the minimum and maximum values of the force that the magnetic field could exert on a proton (charge = 1.6×10^{-19} C) moving with a speed of 10^4 m/s.

खण्ड - य

SECTION - E

24. (a) जब किसी छड़ चुम्बक को, गैल्वेनोमीटर से संयोजित, किसी कुण्डली की ओर अथवा उससे दूर धकेला जाता है, तो गैल्वेनोमीटर का संकेतक विक्षेपित होता है। इस विक्षेपण के लिए उत्तरदायी परिघटना को पहचानिए और उन कारकों का उल्लेख कीजिए जिन पर इस विक्षेपण का परिमाण और दिशा निर्भर करती है। इस परिघटना का वर्णन करने वाले नियमों को लिखिए। 5
- (b) जब कोई लम्बाई l और प्रतिरोध R की चालक छड़ PQ, चित्र में दर्शाए अनुसार एक समान चुम्बकीय क्षेत्र में स्थित किसी आयताकार चालक पर चाल v से A और C के बीच मुक्त रूप से इधर-उधर गति करती है, तो फ्लक्स, emf और बल में परिवर्तन को आरेखित कीजिए।

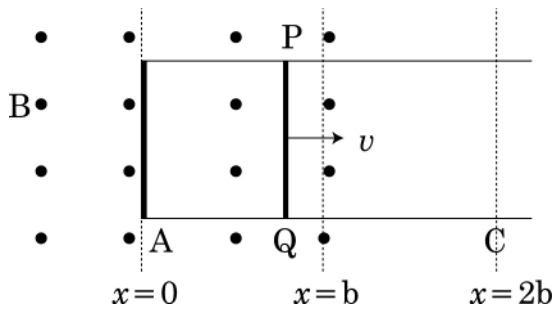

अथवा

किसी a.c. वोल्टता $v = v_m \sin \omega t$ से संयोजित LCR श्रेणी परिपथ में धारा के लिए व्यंजक व्युत्पन्न करने के लिए फ्रेजर आरेख का उपयोग कीजिए। अब इस परिपथ में क्षयित शक्ति के व्यंजक प्राप्त कीजिए। यह दर्शाइए कि अनुनाद के समय अधिकतम शक्ति क्षय होता है।

- (a) When a bar magnet is pushed towards (or away) from the coil connected to a galvanometer, the pointer in the galvanometer deflects. Identify the phenomenon causing this deflection and write the factors on which the amount and direction of the deflection depends. State the laws describing this phenomenon.
- (b) Sketch the change in flux, emf and force when a conducting rod PQ of resistance R and length l moves freely to and fro between A and C with speed v on a rectangular conductor placed in uniform magnetic field as shown in the figure.

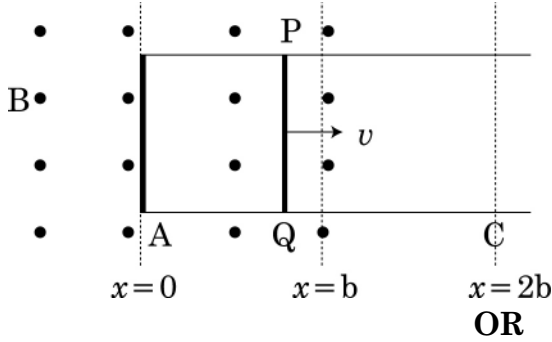

OR

In a series LCR circuit connected to an a.c. source of voltage $v = v_m \sin \omega t$, use phasor diagram to derive an expression for the current in the circuit. Hence obtain the expression for the power dissipated in the circuit. Show that power dissipated at resonance is maximum.

25. (a) घूर्णन करते पोलरॉयड में से देखने पर आने वाले अध्रुवित प्रकाश की तीव्रता में विचरण क्यों दिखाई देता है? 5
आरेख की सहायता से यह दर्शाइए कि प्रकीर्णन द्वारा किस प्रकार सूर्य से आने वाला प्रकाश रैखिकतः ध्रुवित हो जाता है।
- (b) तीन सर्वसम पोलरॉयड शीट P_1 , P_2 और P_3 इस प्रकार अभिविन्यासित हैं कि P_2 और P_3 के पारित अक्ष P_1 के पारित अक्ष से क्रमशः 60° और 90° कोण बनाते हैं। चित्र में दर्शाए अनुसार P_1 के सामने I_0 तीव्रता का कोई अध्रुवित एकवर्णी प्रकाश स्रोत S स्थित है। पोलरॉयड P_3 को P_2 के सापेक्ष कोण $\theta = 30^\circ$ और 60° पर घूर्णन कराने पर किसी प्रेक्षक O द्वारा दिखाई देने वाले प्रकाश की तीव्रताएं ज्ञात कीजिए।

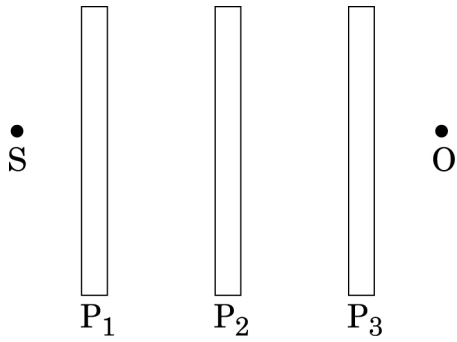

अथवा

- (a) यंग के द्वि झिरी प्रयोग में पथान्तर के लिए व्यंजक व्युत्पन्न कीजिए तथा पर्दे के किसी बिन्दु पर संपोषी व्यतिकरण और विनाशी व्यतिकरण के लिए शर्तें प्राप्त कीजिए।
- (b) यंग के द्वि झिरी प्रयोग में केन्द्रीय उच्चिष्ठ की तीव्रता I_0 है। उस बिन्दु पर तीव्रता ज्ञात कीजिए जहाँ पथान्तर $\frac{\lambda}{6}$, $\frac{\lambda}{4}$ तथा $\frac{\lambda}{3}$ है।

- (a) Why does unpolarised light from a source show a variation in intensity when viewed through a polaroid which is rotated? Show with the help of a diagram, how unpolarised light from sun gets linearly polarised by scattering.
- (b) Three identical polaroid sheets P_1 , P_2 and P_3 are oriented so that the pass axis of P_2 and P_3 are inclined at angles of 60° and 90° respectively with the pass axis of P_1 . A monochromatic source S of unpolarized light of intensity I_0 is kept in front of the polaroid sheet P_1 as shown in the figure. Determine the intensities of light as observed by the observer at O , when polaroid P_3 is rotated with respect to P_2 at angles $\theta = 30^\circ$ and 60° .

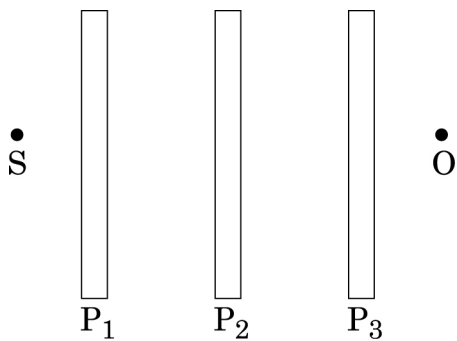

OR

- (a) Derive an expression for path difference in Young's double slit experiment and obtain the conditions for constructive and destructive interference at a point on the screen.
- (b) The intensity at the central maxima in Young's double slit experiment is I_0 . Find out the intensity at a point where the path difference is $\frac{\lambda}{6}$, $\frac{\lambda}{4}$ and $\frac{\lambda}{3}$.

26. (a) उपयुक्त आरेख की सहायता से किसी बाह्य विद्युत् क्षेत्र में स्थित किसी चालक और परावैद्युत के व्यवहार में विभेदन कीजिए। ध्रुवित परावैद्युत किस प्रकार मूल विद्युत क्षेत्र को रूपांतरित करता है? 5
- (b) धारिता C के किसी संधारित्र को emf E की किसी बैटरी द्वारा पूर्णतः आवेशित किया जाता है। इसके पश्चात् इसका बैटरी से सम्पर्क काट दिया जाता है। अब यदि संधारित्र की पट्टिकाओं के बीच का पृथकन दो गुना कर दिया जाए, तो निम्नलिखित में क्या परिवर्तन होगा?
- (i) संधारित्र में संचित आवेश।
(ii) पट्टिकाओं के बीच क्षेत्र की तीव्रता।
(iii) संधारित्र द्वारा संचित ऊर्जा।
प्रत्येक स्थिति में अपने उत्तर की पुष्टि कीजिए।

अथवा

- (a) स्पष्ट कीजिए कि किसी भी आवेश-विन्यास के लिए किसी भी बिन्दु से गुजरने वाला समविभव पृष्ठ उस बिन्दु पर विद्युत् क्षेत्र के अभिलम्बवत होता है। किसी एकल आवेश ($-q$) के कारण समविभव पृष्ठों को आवेश के कारण विद्युत् क्षेत्र रेखाओं को दर्शाते हुए आरेखित कीजिए।
- (b) नीचे आरेख में दर्शाए अनुसार भुजा 'a' के किसी समबाहु त्रिभुज के शीर्षों पर स्थित तीन आवेशों के निकाय को विघटित करने के लिए किए जाने वाले कार्य के लिए व्यंजक प्राप्त कीजिए।

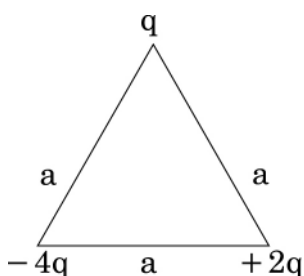

- (a) Distinguish, with the help of a suitable diagram, the difference in the behaviour of a conductor and a dielectric placed in an external electric field. How does polarised dielectric modify the original external field ?
- (b) A capacitor of capacitance C is charged fully by connecting it to a battery of emf E . It is then disconnected from the battery. If the separation between the plates of the capacitor is now doubled, how will the following change ?
- charge stored by the capacitor.
 - field strength between the plates.
 - energy stored by the capacitor.

Justify your answer in each case.

OR

- (a) Explain why, for any charge configuration, the equipotential surface through a point is normal to the electric field at that point.
Draw a sketch of equipotential surfaces due to a single charge ($-q$), depicting the electric field lines due to the charge.
- (b) Obtain an expression for the work done to dissociate the system of three charges placed at the vertices of an equilateral triangle of side 'a' as shown below.

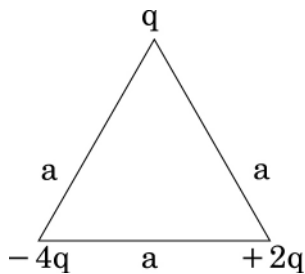

MARKING SCHEME

Q. No.	Expected Answer / Value Points	Marks	Total Marks
Set1,Q1 Set2,Q2 Set3,Q4	SECTION A Zero / No work done / None	1	1
Set1,Q2 Set2,Q5 Set3,Q3	Drift velocity per unit field ($\mu_m = v_d/E$) $\mu_n \propto \tau$ (directly proportional to relaxation time)	1/2 1/2	1
Set1,Q3 Set2,Q4 Set3,Q2	Charged particle moves inclined to the magnetic field (angle between \vec{v} and \vec{B} is neither $\pi/2$ nor 0) (component of \vec{v} , parallel to \vec{B} , is not zero.)	1	1
Set1,Q4 Set2,Q1 Set3,Q5	(some) light gets deviated / scattered / absorbed Scattering of light	1/2 1/2	1
Set1,Q5 Set2,Q3 Set3,Q1	$v_{side\ bands} = v_c \pm v_m$ = 2005 kHz ; 1995 kHz (Give full 1 mark if the student straightaway writes the answer as 2005 kHz and 1995 kHz)	1/2 1/2	1
Set1,Q6 Set2,Q8 Set3,Q7	SECTION B		
	Formulae: 1 Substitution and calculation: 1		
	$R = \rho \frac{l}{A}; I = neAv_d$ $\therefore \rho = \frac{V}{neV_d}$ Alternatively, $\left(j = \sigma E = \frac{E}{\rho} \text{ or } \frac{E}{j} = \rho \right)$ $\therefore \rho = \frac{V}{Inev_d}$	1/2 1/2	
	(Award this 1 mark even if the student writes the formula for ρ directly as such)		
	$\therefore \rho = \frac{5}{0.1 \times 8 \times 10^{28} \times 1.6 \times 10^{-19} \times 2.5 \times 10^{-4}} \Omega - m$ $= 1.56 \times 10^{-5} \Omega - m$ $\approx 1.6 \times 10^{-5} \Omega - m$	1/2 1/2	2



Set1,Q7 Set2,Q10 Set3,Q8	<table border="1"> <tbody> <tr> <td>Formulae</td> <td>$\frac{1}{2} + \frac{1}{2}$</td> </tr> <tr> <td>Conclusions in the two cases</td> <td>$\frac{1}{2} + \frac{1}{2}$</td> </tr> </tbody> </table>	Formulae	$\frac{1}{2} + \frac{1}{2}$	Conclusions in the two cases	$\frac{1}{2} + \frac{1}{2}$	$\frac{1}{2}$	$\frac{1}{2}$	$\frac{1}{2}$	$\frac{1}{2}$	2
Formulae	$\frac{1}{2} + \frac{1}{2}$									
Conclusions in the two cases	$\frac{1}{2} + \frac{1}{2}$									
Set1,Q8 Set2,Q9 Set3,Q6	<table border="1"> <tbody> <tr> <td>Indicating the transition</td> <td>1</td> </tr> <tr> <td>Calculation of frequency</td> <td>1</td> </tr> </tbody> </table>	Indicating the transition	1	Calculation of frequency	1	1	$\frac{1}{2}$	$\frac{1}{2}$	$\frac{1}{2}$	2
Indicating the transition	1									
Calculation of frequency	1									
	<p>When the electron jumps from the orbit with $n=3$ to $n=2$ (Longest wavelength of the Balmer series / First line of the Balmer series)</p> $h\nu = E_3 - E_2 = \frac{E_1}{9} - \frac{E_1}{4}$ $= \frac{-5}{36} E_1 = \frac{-5}{36} \times (-13.6 \text{ eV})$ $= \frac{5}{36} \times 13.6 \times 1.6 \times 10^{-19} \text{ J}$ $\therefore \nu = \frac{5 \times 13.6 \times 1.6 \times 10^{-19}}{36 \times 6.63 \times 10^{-34}} \text{ Hz}$ $\approx 4.57 \times 10^{14} \text{ Hz.}$ <p>(If the student just writes $\nu = \frac{-5}{36} \frac{E_1}{h}$, award $\frac{1}{2}$ mark)</p> <p>(Alternatively,</p> $\frac{1}{\lambda} = R \left(\frac{1}{2^2} - \frac{1}{3^2} \right) = \frac{5}{36} R$ $\therefore \nu = \frac{c}{\lambda}$ $= c \times \frac{5}{36} R$ $= 3 \times 10^8 \times \frac{5}{36} \times 1.097 \times 10^7 \text{ Hz}$ $\approx 4.57 \times 10^{14} \text{ Hz})$	$\frac{1}{2}$								



	OR								
	<table border="1" style="width: 100%;"> <tr> <td>Formula</td> <td style="text-align: right;">1</td> </tr> <tr> <td>Calculation of λ</td> <td style="text-align: right;">1</td> </tr> </table>	Formula	1	Calculation of λ	1				
Formula	1								
Calculation of λ	1								
	$\frac{1}{\lambda} = R \left(\frac{1}{1^2} - \frac{1}{\infty^2} \right)$ $\therefore \lambda = \frac{1}{R}$ $= \frac{1}{1.097 \times 10^7} \text{ m}$ $\approx 9.116 \times 10^{-8} \text{ m}$ $\approx 912 \text{ \AA} \text{ (91.2 nm)}$	1/2 1/2 1	2						
Set1,Q9 Set2,Q6 Set3,Q10	<table border="1" style="width: 100%;"> <tr> <td>Two Reasons 1+ 1</td> </tr> </table> <p>If base band signal were to be transmitted directly</p> <ol style="list-style-type: none"> 1. The height of the antennae needed will be impractically large. 2. The effective power radiated would be too low. 3. There would be a high probability of different signals getting mixed up with one another. <p>(Any two)</p>	Two Reasons 1+ 1	1+1	2					
Two Reasons 1+ 1									
Set1,Q10 Set2,Q7 Set3,Q9	<table border="1" style="width: 100%;"> <tr> <td>Identifying that θ is the angle of minimum deviation</td> <td style="text-align: right;">1/2</td> </tr> <tr> <td>Formula</td> <td style="text-align: right;">1/2</td> </tr> <tr> <td>Calculation of θ</td> <td style="text-align: right;">1</td> </tr> </table> <p>Since AQ = AR, we have QR BC $\therefore \theta$ is the angle of minimum deviation.</p> <p>(Alternatively: Since AQ=AR, we get $\angle r_1 = \angle r_2$ $\therefore \theta$ is the angle of minimum deviation.)</p> $\mu = \frac{\sin\left(\frac{A + \delta m}{2}\right)}{\sin(A/2)}$ $\therefore \sqrt{3} = \frac{\sin\left(\frac{60 + \delta m}{2}\right)}{\sin 30^\circ}$ $\therefore \frac{\sqrt{3}}{2} = \sin\left(\frac{60 + \delta m}{2}\right)$ $\therefore \frac{60 + \delta m}{2} = 60$ <p>or $\delta m = 60^\circ$</p>	Identifying that θ is the angle of minimum deviation	1/2	Formula	1/2	Calculation of θ	1	1/2 1/2 1/2 1/2	2
Identifying that θ is the angle of minimum deviation	1/2								
Formula	1/2								
Calculation of θ	1								

SECTION C

Set1,Q11
Set2,Q17
Set3,Q22

Statement of Gauss's Law	1/2
Calculation of field	
(i) Outside the shell	1
(ii) Inside the shell	1
Graph	1/2

We have by Gauss's law $\oint \vec{E} \cdot \vec{dS} = \frac{Q_{enclosed}}{\epsilon_0}$

Let Q be the total charge on the shell

(i) For the point M outside the shell, we have

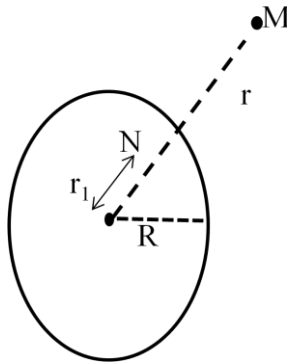

$$E \cdot 4\pi r^2 = \frac{Q}{\epsilon_0}$$

$$\therefore E = \frac{1}{4\pi\epsilon_0} \frac{Q}{r^2}$$

(ii) For the point N inside the shell, as charge enclosed inside the shell is zero.

$$E \cdot 4\pi r_1^2 = 0$$

$$\therefore E = 0$$

The graph is as shown

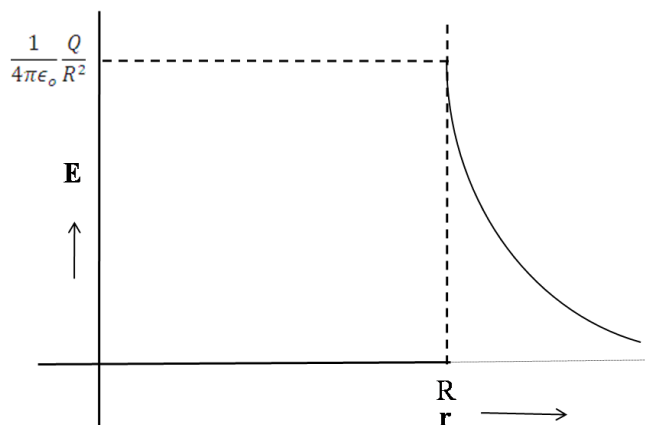

1/2

1/2

1/2

1/2

1/2

1/2

3

Set1,Q12
Set2,Q19
Set3,Q21

Formulae
Calculation of r

1
2

We have, for a single cell,

$$r = \left(\frac{E}{V} - 1 \right) R$$

\therefore For the parallel combination, as given in the question,

$$\frac{r}{2} = \left(\frac{E}{V} - 1 \right) \frac{R}{2}$$

$$\therefore r = \left(\frac{1.5}{1.4} - 1 \right) \times 7 \Omega$$

$$= \frac{0.1}{1.4} \times 7 \Omega$$

$$= 0.5 \Omega$$

(Alternatively,

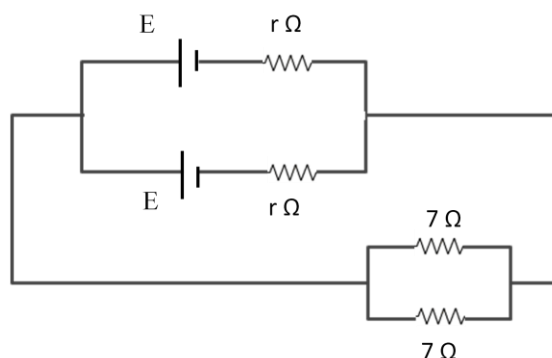

$$I = \frac{V}{(R/2)}$$

$$\text{And } E = V - I(r/2)$$

$$\text{This gives } I = \frac{1.4}{7/2} \text{ A} = 0.4 \text{ A}$$

$$\therefore \frac{r}{2} = \frac{1.5 - 1.4}{0.4} = 0.25$$

$$\therefore r = 0.5 \Omega$$

(Note: If the student just draws the circuit diagram of the setup but does not do any calculations, award 1 mark only.)

1

$\frac{1}{2}$

$\frac{1}{2}$

$\frac{1}{2}$

$\frac{1}{2}$

$\frac{1}{2}$

$\frac{1}{2}$

$\frac{1}{2}$

$\frac{1}{2}$

$\frac{1}{2}$

$\frac{1}{2}$

3



Set1,Q13 Set2,Q21 Set3,Q20	<table border="1"> <tr> <td>Statement of Ampere’s Circuital law</td> <td>1</td> </tr> <tr> <td>Finding Magnetic Field</td> <td>1 ½</td> </tr> <tr> <td>Differences between the two types of field lines</td> <td>½</td> </tr> </table>	Statement of Ampere’s Circuital law	1	Finding Magnetic Field	1 ½	Differences between the two types of field lines	½	1	3
Statement of Ampere’s Circuital law	1								
Finding Magnetic Field	1 ½								
Differences between the two types of field lines	½								
According to Ampers’s circuital law, “ The line integral of the magnetic field, around a closed loop, equals μ_o times the total current passing through the surface enclosed by that loop.”									
Alternatively,									
$\oint \vec{B} \cdot \vec{dl} = \mu_o I$ For the infinite current carrying wire, we get $B \cdot \oint dl = \mu_o I$ or $B 2\pi r = \mu_o I$ or $B = \frac{\mu_o I}{2\pi r}$		½ ½ ½							
The magnetic field lines form closed loops while the electric field lines originate from positive charges and end at negative charges.		½							
OR									
<table border="1"> <tr> <td>Principle of cyclotron</td> <td>1</td> </tr> <tr> <td>Independence of time period from speed</td> <td>1 ½</td> </tr> <tr> <td>Necessity of this property</td> <td>½</td> </tr> </table>		Principle of cyclotron	1	Independence of time period from speed	1 ½	Necessity of this property	½		
Principle of cyclotron	1								
Independence of time period from speed	1 ½								
Necessity of this property	½								
The cyclotron uses both electric and magnetic fields, in combination, to increase the energy of the charged particles.		1							
(Alternatively: Cyclotron uses (i) A magnetic field to make the charged particles move in a circular path. (ii) An alternating electric field which accelerates the charged particles as they repeatedly cross it in a way that makes them gain energy continuously.)									
We have $\frac{mv^2}{r} = qvB$		½							

	$\therefore r = \frac{mv}{qB}$ <p>Also $T = \frac{2\pi r}{v}$</p> $\therefore T = \frac{2\pi m}{qB}$ <p>$\therefore T$ is independent of v, the speed of the charged particles.</p> <p>This property ensures that if the frequency of the applied alternating electric field matches the cyclotron frequency, the particle would keep on getting accelerated every time it crosses the gap between the dees.</p> <p>(Alternatively : Because of the property, the applied alternating electric field can be made to accelerate the charged particles continuously. This property ensures that the resonance condition can be satisfied and the particle gets accelerated continuously. This property ensures that we can have $\vartheta = \vartheta_c$, the resonance condition.)</p>	<p>$\frac{1}{2}$</p> <p>$\frac{1}{2}$</p> <p>$\frac{1}{2}$</p> <p>3</p>					
Set1,Q14 Set2,Q14 Set3,Q19	<table border="1" style="width: 100%; border-collapse: collapse;"> <tbody> <tr> <td style="padding: 5px;">Showing that the average power, over a complete cycle is zero</td> <td style="text-align: right; padding: 5px;">2</td> </tr> <tr> <td style="padding: 5px;">Effect on brightness of bulb</td> <td style="text-align: right; padding: 5px;">1</td> </tr> </tbody> </table> <p>(i) Let the applied voltage be</p> $V = V_0 \sin \omega t$ <p>The current through an ideal capacitor, would then be</p> $I = I_0 \sin \left(\omega t + \frac{\pi}{2} \right) = I_0 \cos \omega t$ $\therefore P_{inst} = VI$ $\therefore P_{AV} = \frac{1}{T} \int_0^T VI dt$ $\therefore P_{AV} = \frac{V_0 I_0}{2} \langle \sin 2\omega t \rangle$ $= 0$ <p>(Alternatively , For an ideal capacitor, the current leads voltage in phase by $\pi/2$. $\therefore P = \frac{E_0 I_0}{\sqrt{2} \sqrt{2}} \cos \Phi = \frac{E_0 I_0}{2} \cos \frac{\pi}{2}$ $= 0$)</p> <p>(ii) The brightness of the bulb would also reduce gradually. (Alternatively: $X_c = \frac{1}{\omega C}$ $\therefore X_c$ increases as C decreases. Hence, with decreasing C, the brightness of the bulb would decrease.)</p>	Showing that the average power, over a complete cycle is zero	2	Effect on brightness of bulb	1	<p>$\frac{1}{2}$</p> <p>$\frac{1}{2}$</p> <p>$\frac{1}{2}$</p> <p>$\frac{1}{2}$</p> <p>1</p> <p>3</p>	
Showing that the average power, over a complete cycle is zero	2						
Effect on brightness of bulb	1						



Set1,Q15 Set2,Q22 Set3,Q18	<table border="1"> <tr> <td>Production of e.m. waves</td> <td>1/2</td> </tr> <tr> <td>Source of energy</td> <td>1/2</td> </tr> <tr> <td>Expressions for electric and magnetic fields</td> <td>1/2 + 1/2</td> </tr> <tr> <td>Any two properties</td> <td>1/2 + 1/2</td> </tr> </table>	Production of e.m. waves	1/2	Source of energy	1/2	Expressions for electric and magnetic fields	1/2 + 1/2	Any two properties	1/2 + 1/2	<p>1/2</p> <p>1/2</p> <p>1/2</p> <p>1/2</p> <p>1/2 + 1/2</p>	<p>3</p>
Production of e.m. waves	1/2										
Source of energy	1/2										
Expressions for electric and magnetic fields	1/2 + 1/2										
Any two properties	1/2 + 1/2										
Set1,Q16 Set2,Q15 Set3,Q17	<table border="1"> <tr> <td>(i) Derivation of Snell's law</td> <td>2</td> </tr> <tr> <td>(ii) Sketches to differentiate between plane wavefront and spherical wavefront</td> <td>1</td> </tr> </table>	(i) Derivation of Snell's law	2	(ii) Sketches to differentiate between plane wavefront and spherical wavefront	1	<p>1/2</p> <p>1/2</p> <p>1/2</p>					
(i) Derivation of Snell's law	2										
(ii) Sketches to differentiate between plane wavefront and spherical wavefront	1										

ε.M. waves are produced by accelerated /oscillating charges.

Source of energy is the source that accelerates the charges

Expression for the electric and magnetic fields (for an e.m. wave propagating along the z – axis) can be

$$E_x = E_0 \sin(kz - wt)$$

$$B_y = B_0 \sin(kz - wt)$$

Properties (any two)

- (i) Transverse nature
- (ii) Have a definite speed (for all frequencies) in vaccum
- (iii) Can be polarized
- (iv) Can show the phenomenon of interference and diffraction
- (v) Can transport energy from one point to another
- (vi) Have oscillating electric and magnetic fields along mutually perpendicular directions
- (vii) Have a momentum associated with them.
- (viii) Their speed , in a medium , depends upon the values of μ and ϵ for that medium.

(i)

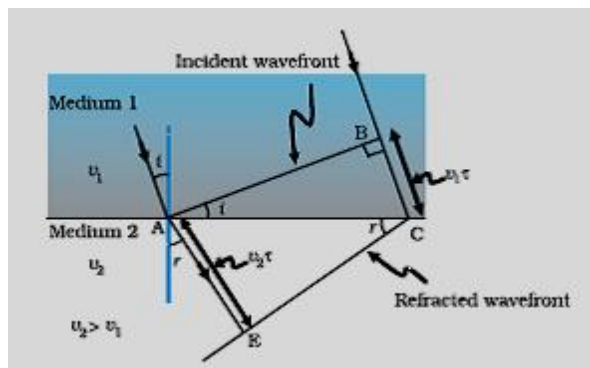

We have $BC = v_1 \tau$ and $AE = v_2 \tau$

Also $\sin i = \frac{BC}{AC}$ and $\sin r = \frac{AE}{AC}$

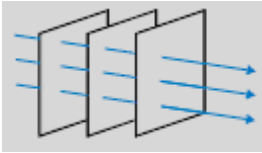
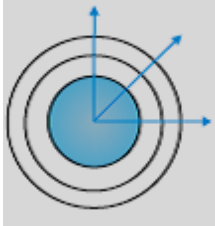
	<p> $\therefore \frac{\sin i}{\sin r} = \frac{BC}{AE} = \frac{\vartheta_1}{\vartheta_2} = \frac{n_2}{n_1}$ = a constant This is Snell's law. </p> <p>(ii) Plane wavefront</p>  <p>Spherical wavefront</p> 	<p>1/2</p> <p>1/2</p> <p>1/2</p>	<p>3</p>										
<p>Set1,Q17 Set2,Q11 Set3,Q16</p>	<table border="1" data-bbox="284 976 1209 1186"> <tr> <td>Two properties of Photon</td> <td>1/2 + 1/2</td> </tr> <tr> <td>Writing Einstein's equation</td> <td>1/2</td> </tr> <tr> <td>Definition of stopping potential (V_0)</td> <td>1/2</td> </tr> <tr> <td>Definition of Threshold frequency (ν_0)</td> <td>1/2</td> </tr> <tr> <td>Plot between V_0 and ν</td> <td>1/2</td> </tr> </table> <p>Properties of Photon</p> <p>(i) For a radiation of frequency ν, each photon has an energy, $E = h\nu$, associated with it</p> <p>(ii) The energy of a photon is independent of the intensity of incident radiation.</p> <p>(iii) During the collision of a photon, with an electron, the total energy of the photon gets absorbed by the electron. (Any two)</p> <p>Einstein's photoelectric equation is</p> <p>$K_{max} = h\nu - \phi_0$ or $eV_0 = h\nu - \phi_0$</p> <p>(a) Stopping potential, V_0, equals that value of the negative potential for which $eV_0 = K_{max}$</p>	Two properties of Photon	1/2 + 1/2	Writing Einstein's equation	1/2	Definition of stopping potential (V_0)	1/2	Definition of Threshold frequency (ν_0)	1/2	Plot between V_0 and ν	1/2	<p>1/2 + 1/2</p> <p>1/2</p> <p>1/2</p>	
Two properties of Photon	1/2 + 1/2												
Writing Einstein's equation	1/2												
Definition of stopping potential (V_0)	1/2												
Definition of Threshold frequency (ν_0)	1/2												
Plot between V_0 and ν	1/2												

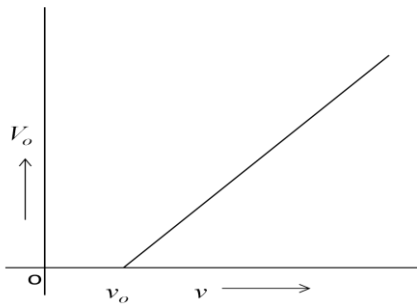
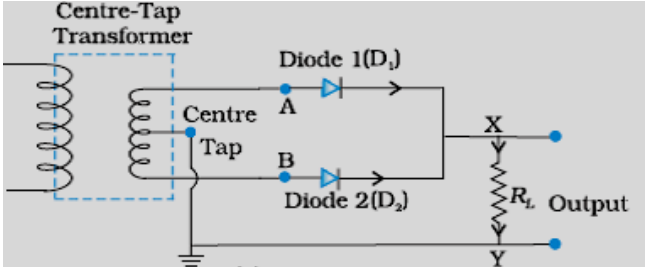
	<p>(Alternatively: The stopping potential (V_0) equals that (least) value of the (negative) plate potential that just stops the most energetic emitted photoelectrons from reaching the plate.)</p> <p>(b) Threshold frequency (ν_0) equals that value of the frequency of incident radiation for which $K_{max} = 0$.</p> <p>(Alternatively: For a given photosensitive surface, its threshold frequency is the minimum value of the frequency of incident radiation for which photoelectrons can be just emitted from that surface or that maximum frequency of incident radiation below which no photo emission takes place.)</p> <p>The plot, between V_0 and ν, has the form shown:</p> 	<p>1</p> <p>$\frac{1}{2}$</p> <p>3</p>									
<p>Set1,Q18 Set2,Q20 Set3,Q15</p>	<table border="1" data-bbox="269 1140 1235 1318"> <tr> <td>(i) Naming the two processes</td> <td>$\frac{1}{2} + \frac{1}{2}$</td> </tr> <tr> <td>(ii) Circuit diagram</td> <td>1</td> </tr> <tr> <td>Input and output waveforms</td> <td>$\frac{1}{2}$</td> </tr> <tr> <td>Unidirectional nature of output voltage/current</td> <td>$\frac{1}{2}$</td> </tr> </table> <p>(i) Diffusion and Drift [Also accept if the student writes</p> <ol style="list-style-type: none"> Appearance of a BARRIER POTENTIAL across the junction. Formation of a DEPLETION REGION on either side of the junction.] <p>(ii) Circuit diagram</p> 	(i) Naming the two processes	$\frac{1}{2} + \frac{1}{2}$	(ii) Circuit diagram	1	Input and output waveforms	$\frac{1}{2}$	Unidirectional nature of output voltage/current	$\frac{1}{2}$	<p>$\frac{1}{2} + \frac{1}{2}$</p> <p>1</p>	
(i) Naming the two processes	$\frac{1}{2} + \frac{1}{2}$										
(ii) Circuit diagram	1										
Input and output waveforms	$\frac{1}{2}$										
Unidirectional nature of output voltage/current	$\frac{1}{2}$										

Input and Output waveforms.

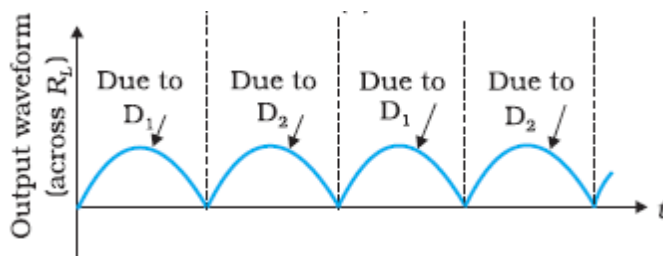
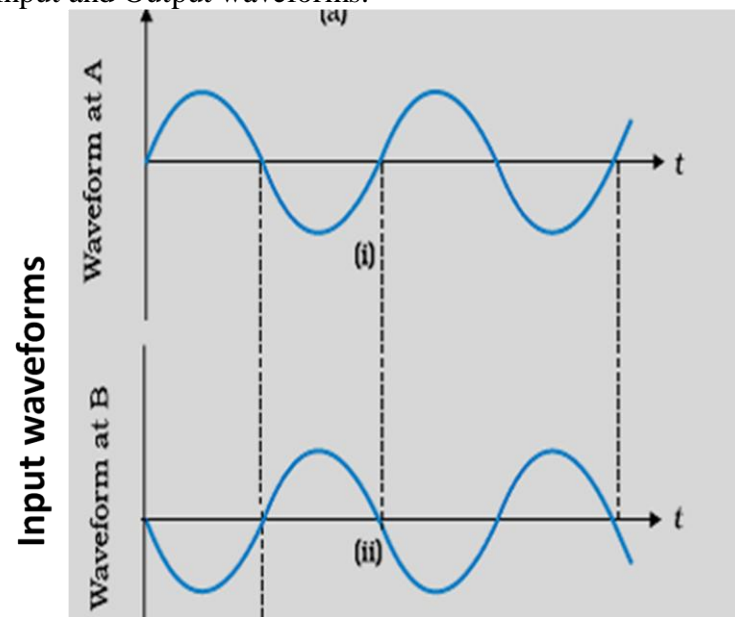

[Note: Award this 1/2 mark even if the student draws the output waveform only.]

Because of (i) the use of the centre tap transformer and (ii) the manner in which the load is connected, the voltage across/current through, the load has the same direction during both halves of the input wave.

1/2

1/2



3

Set1,Q19
Set2,Q12
Set3,Q14

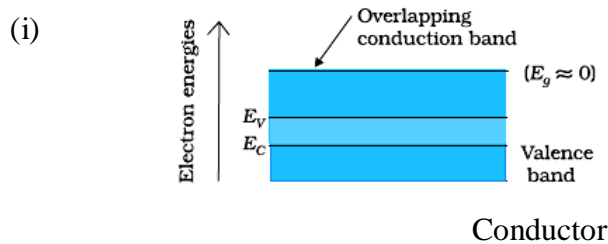
(i)	Distinguishing on the basis of energy band diagram	1/2+1/2
(ii)	Identifying the gate	1
	Truth Table	1/2
	Logic symbol	1/2

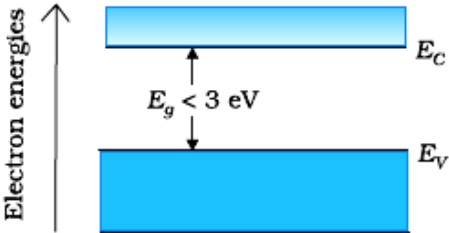

1/2

	<div style="text-align: center;">  <p>Semiconductor</p> </div> <p>(i) The gate is a NAND gate</p> <p><u>Truth Table of NAND gate</u></p> <table border="1" data-bbox="425 714 673 955"> <thead> <tr> <th colspan="2">Input</th> <th>Output</th> </tr> <tr> <th>A</th> <th>B</th> <th>Y</th> </tr> </thead> <tbody> <tr> <td>0</td> <td>0</td> <td>1</td> </tr> <tr> <td>0</td> <td>1</td> <td>1</td> </tr> <tr> <td>1</td> <td>0</td> <td>1</td> </tr> <tr> <td>1</td> <td>1</td> <td>0</td> </tr> </tbody> </table> <p><u>Logic Symbol</u></p> 	Input		Output	A	B	Y	0	0	1	0	1	1	1	0	1	1	1	0	<p>1/2</p> <p>1</p> <p>1/2</p> <p>1/2</p> <p>3</p>	
Input		Output																			
A	B	Y																			
0	0	1																			
0	1	1																			
1	0	1																			
1	1	0																			
<p>Set1,Q20 Set2,Q18 Set3,Q13</p>	<table border="1" data-bbox="284 1249 1226 1386"> <tr> <td>Space wave propagation</td> <td>1</td> </tr> <tr> <td>Factors that limit the range of propagation</td> <td>1/2</td> </tr> <tr> <td>Derivation of the expression</td> <td>1 1/2</td> </tr> </table> <p><u>Space Wave Propagation</u> The mode of propagation in which radio waves travel, along a straight line, from the transmitting to the receiving antenna.</p> <p><u>Limiting Factors</u></p> <p>(i) Curvature of the earth (ii) Insufficient height of the receiving antenna (Award this 1/2 mark if the student writes any one of these two factors)</p>	Space wave propagation	1	Factors that limit the range of propagation	1/2	Derivation of the expression	1 1/2	<p>1</p> <p>1/2</p>													
Space wave propagation	1																				
Factors that limit the range of propagation	1/2																				
Derivation of the expression	1 1/2																				

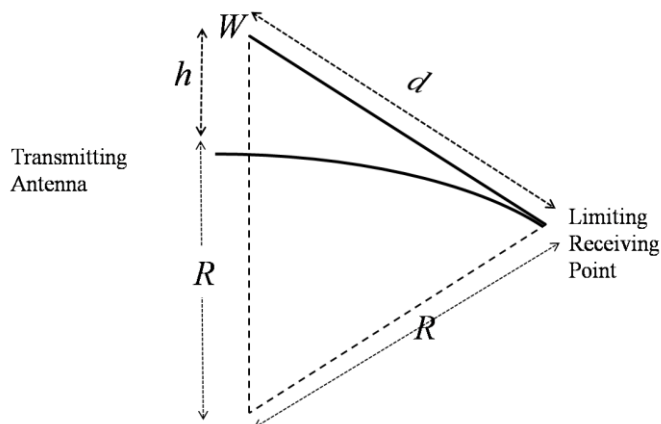
Derivation

From the figure, we have

$$(R + h)^2 = R^2 + d^2$$

Or

$$2Rh \cong d^2 \text{ (as } h^2 \ll 2Rh)$$

$$\therefore, d = \sqrt{2Rh}$$

For a transmitting antenna of height h_T , and a receiving antenna of height h_R , the maximum line of sight distance becomes

$$d_M = \sqrt{2Rh_T} + \sqrt{2Rh_R}$$

[NOTE: Give 1 mark if the student writes the expression for d_M]

Set1,Q21
Set2,Q13
Set3,Q12

- | | | |
|------|---|----|
| (i) | Derivation of the mathematical expression | 2½ |
| (ii) | Relation between mean life and decay constant | ½ |

- (i) Let there be N_0 radioactive nuclei at $t=0$.
If N is the number of nuclei left over at $t=t$, we have

$$\frac{-dN}{dt} \propto N$$

$$\text{or } \frac{-dN}{dt} = \lambda N \text{ (} \lambda = \text{decay constant)}$$

$$\therefore \frac{dN}{N} = -\lambda dt$$

$$\text{or } \ln N = -\lambda t + \text{constant}$$

\therefore At $t=0$, we have

$$\ln N_0 = \text{constant}$$

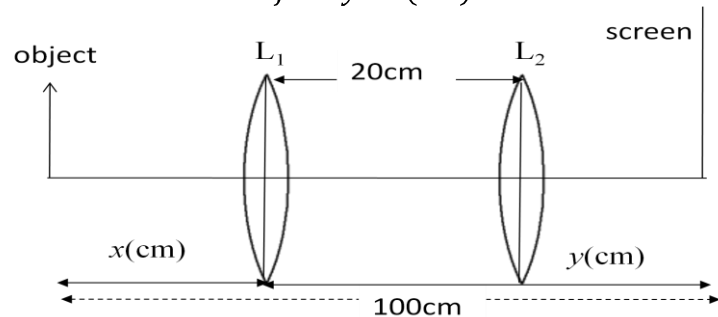

	$\ln N = -\lambda t + \ln N_0$ $\text{or } \ln \left(\frac{N}{N_0} \right) = -\lambda t$ $\therefore N = N_0 e^{-\lambda t}$ <p>(ii) Mean life = $\frac{1}{\text{decay constant}}$</p> <p>(Alternatively, $\tau = \frac{1}{\lambda}$)</p>	$\frac{1}{2}$ $\frac{1}{2}$	3
Set1,Q22 Set2,Q16 Set3,Q11	<div style="border: 1px solid black; padding: 5px; margin-bottom: 10px;"> <p>(i) Calculating the focal length of the lens 2</p> <p>(ii) Calculating the focal length of the combination 1</p> </div> <p>(i) For first position of the lens , we have</p> $\frac{1}{f} = \frac{1}{y} - \frac{1}{(-x)}$  <p>For second position of the lens , we have</p> $\frac{1}{f} = \frac{1}{y-20} - \frac{1}{-(x+20)}$ $\frac{1}{y} + \frac{1}{x} = \frac{1}{(y-20)} + \frac{1}{(x+20)}$ $\frac{x+y}{xy} = \frac{(x+20) + (y-20)}{(y-20)(x+20)}$ $\therefore xy = (y-20)(x+20)$ $= xy - 20x + 20y - 400$ $\therefore x - y = -20$ <p>Also , $x + y = 100$ $\therefore x = 40 \text{ cm}$ and $y = 60 \text{ cm}$</p> $\therefore \frac{1}{f} = \frac{1}{60} - \frac{1}{-40} = \frac{2+3}{120} = \frac{5}{120}$ $\therefore f = 24 \text{ cm}$	$\frac{1}{2}$ $\frac{1}{2}$ $\frac{1}{2}$	



Alternatively ,

We have

$$f = \frac{D^2 - d^2}{4D}$$

$$= \frac{100^2 - 20^2}{4 \times 100}$$

$$= \frac{120 \times 80}{400}$$

$$= 24 \text{ cm}$$

Alternatively,

For the two positions of the lens , the values of the magnitudes of u and v , get interchanged.

Hence , $|u + v| = 100$

$|u - v| = 20$, This gives $|u| = 60$ $|v| = 40$

$\therefore f = 24 \text{ cm}$

Alternatively ,

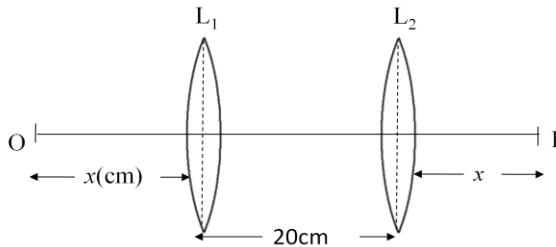

$$2x + 20 = 100$$

$$\therefore x = 40 \text{ cm}$$

For lens at position L₁ ; $u = -x = -40 \text{ cm}$

$$v = 20 + 40 = 60 \text{ cm}$$

This gives $f = 24 \text{ cm}$

(i) For combination of two lenses in contact .

Net Power of combination ,

$$P = P_1 + P_2$$

$$P_1 = +P , P_2 = -P$$

So $P = 0$ and $F = \text{infinite}$

Alternatively , $\frac{1}{F} = \frac{1}{f_1} + \frac{1}{f_2}$

1

 $\frac{1}{2}$ $\frac{1}{2}$ $\frac{1}{2}$ $\frac{1}{2}$ $\frac{1}{2}$ $\frac{1}{2}$ $\frac{1}{2}$ $\frac{1}{2}$ $\frac{1}{2}$ $\frac{1}{2}$ $\frac{1}{2}$ $\frac{1}{2}$ $\frac{1}{2}$ 

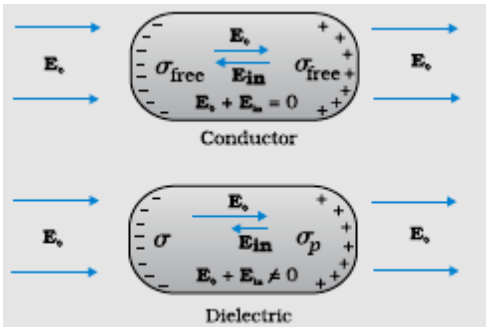
	$= \frac{1}{f} + \left(\frac{-1}{f}\right) = 0$ <p>F = infinite</p>	1/2											
Set1,Q23 Set2,Q23 Set3,Q23	<table border="1" style="width: 100%;"> <tr> <td>(a) Values displayed</td> <td style="text-align: right;">1/2 + 1/2 + 1/2</td> </tr> <tr> <td>(b) Possible reason</td> <td style="text-align: right;">1/2</td> </tr> <tr> <td>(c) Formula for force</td> <td style="text-align: right;">1/2</td> </tr> <tr> <td> Max. value</td> <td style="text-align: right;">1</td> </tr> <tr> <td> Min. value</td> <td style="text-align: right;">1/2</td> </tr> </table> <p>a) Value displayed by Seema : Helpful , considerate Family : Concerned , Affectionate Doctor : Humane nature (any one in all three cases)</p> <p>b) Expensive machinery/technique</p> <p>c) $F = qvB\sin\theta$ $F_{max} = qvB = 1.6 \times 10^{-19} \times 10^4 \times 0.1$ $= 1.6 \times 10^{-16}N$</p> <p>$F_{min} = \text{zero}$ (for $\theta = 0^\circ$)</p>	(a) Values displayed	1/2 + 1/2 + 1/2	(b) Possible reason	1/2	(c) Formula for force	1/2	Max. value	1	Min. value	1/2	<p>1/2</p> <p>1/2</p> <p>1/2</p> <p>1/2</p> <p>1</p> <p>1/2</p>	4
(a) Values displayed	1/2 + 1/2 + 1/2												
(b) Possible reason	1/2												
(c) Formula for force	1/2												
Max. value	1												
Min. value	1/2												
Set1,Q24 Set2,Q25 Set3,Q26	SECTION E												
	<table border="1" style="width: 100%;"> <tr> <td>a) Difference between the behaviours of the two Modification of electric field.</td> <td style="text-align: right;">(1/2 + 1/2)</td> </tr> <tr> <td>b) (i) Charge stored + justification</td> <td style="text-align: right;">1</td> </tr> <tr> <td> (ii) field strength + justification</td> <td style="text-align: right;">1/2 + 1/2</td> </tr> <tr> <td> (iii) energy stored + justification</td> <td style="text-align: right;">1/2 + 1/2</td> </tr> </table> <p>a)</p>  <p>No electric field inside a conductor . (Give full credit to diagram. Give 1/2 mark if explanation only is given without</p>	a) Difference between the behaviours of the two Modification of electric field.	(1/2 + 1/2)	b) (i) Charge stored + justification	1	(ii) field strength + justification	1/2 + 1/2	(iii) energy stored + justification	1/2 + 1/2	1/2 + 1/2			
a) Difference between the behaviours of the two Modification of electric field.	(1/2 + 1/2)												
b) (i) Charge stored + justification	1												
(ii) field strength + justification	1/2 + 1/2												
(iii) energy stored + justification	1/2 + 1/2												

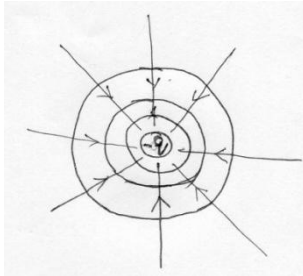
	<p>diagram)</p> <p>Induced electric field ,due to polarisation of dielectric, is in opposite direction to the applied field.</p> $E_{net} = E_0 - E_\rho$ <p>(b)</p> <p>(i) Charge remains same, as after disconnecting capacitor no transfer of charge take place.</p> <p>(ii) Electric field, $E = \frac{\sigma}{\epsilon_0} = \frac{q}{\epsilon_0 A}$ remain same, as there is no change in charge.</p> <p>(iii) Energy stored = $\frac{q^2}{2C} = \frac{q^2}{2(\frac{\epsilon_0 A}{d})} = \frac{q^2 d}{2\epsilon_0 A}$</p> <p>a. Energy will be doubled as separation between the plates(d) is doubled.</p> <p style="text-align: center;">OR</p> <div style="border: 1px solid black; padding: 5px; margin: 10px 0;"> <p>a) Why is electric field normal to the equipotential surface. 1 ½ Sketch of the equipotential surface and electric field lines. ½ + ½</p> <p>b) Obtaining the expression for the work done. 2 ½</p> </div> <p>(a) If the field is not normal to an equipotential surface, it would have a non zero component along the surface. This would imply that work would have to be done to move a charge on the surface which is contradictory to the definition of equipotential surface.</p> <p>(Alternatively, Work done to move a charge dq, on a surface, can be expressed as $dW = dq(\vec{E} \cdot \vec{dr})$ But $dW=0$ on an equipotential surface $\therefore \vec{E} \perp \vec{dr}$ Equipotential surfaces for a charge -q</p> <div style="text-align: center; margin: 10px 0;">  </div> <p>(b) Work done to dissociate the system = -Potential energy of the system</p>	<p>1</p> <p>½ + ½</p> <p>½ + ½</p> <p>½</p> <p>½</p> <p>5</p> <p>1 ½</p> <p>½</p> <p>½</p> <p>½</p> <p>½ + ½</p> <p>½</p>	<p>5</p>
--	--	---	----------

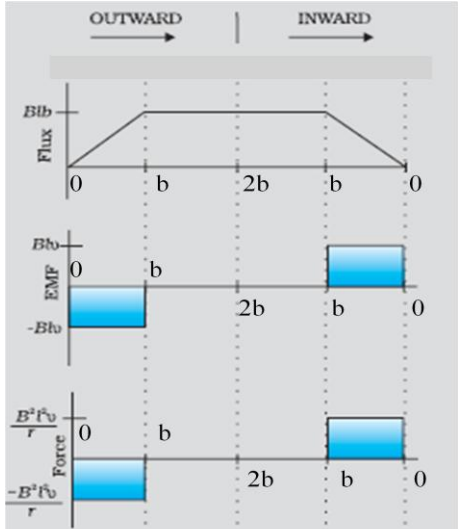
	$= \frac{-1}{4\pi\epsilon_0} \left[\frac{(-4q)(q)}{a} + \frac{(2q)(q)}{a} + \frac{(-4q)(2q)}{a} \right]$ $= -\frac{1}{4\pi\epsilon_0 a} [-4q^2 + 2q^2 - 8q^2]$ $= + \left[\frac{10q^2}{4\pi\epsilon_0 a} \right]$	<p>1 1/2 1/2</p>	<p>5</p>														
<p>Set1,Q25 Set2,Q26 Set3,Q24</p>	<table border="1" style="width: 100%; border-collapse: collapse;"> <tr> <td style="padding: 5px;">(a) Identification of phenomenon</td> <td style="text-align: right; padding: 5px;">1/2</td> </tr> <tr> <td style="padding: 5px;"> Stating the factors</td> <td style="text-align: right; padding: 5px;">1/2 + 1/2</td> </tr> <tr> <td style="padding: 5px;"> Law</td> <td style="text-align: right; padding: 5px;">1/2</td> </tr> <tr> <td style="padding: 5px;">(b) Sketch of change in</td> <td></td> </tr> <tr> <td style="padding: 5px;"> i. Flux</td> <td style="text-align: right; padding: 5px;">1</td> </tr> <tr> <td style="padding: 5px;"> ii. Emf</td> <td style="text-align: right; padding: 5px;">1</td> </tr> <tr> <td style="padding: 5px;"> iii. Force</td> <td style="text-align: right; padding: 5px;">1</td> </tr> </table> <p>(a) The phenomenon involved is electromagnetic induction (EMI) 1/2 For the deflection: 1/2 Amount depends upon the speed of movement of the magnet. 1/2 Direction depends on the sense (towards, or away) of the movement of the magnet. 1/2 The law describing the phenomenon is : The magnitude of the induced emf, in a circuit, is equal to the time rate of change of the magnetic flux through the circuit. 1/2</p> <p>(Note: Also accept if a student writes: whenever magnetic flux linked with a conductor changes, an induced emf is setup in the conductor.)</p> <p>(Alternatively, $\epsilon = -\frac{d\phi_B}{dt}$)</p> <p>(b) </p>	(a) Identification of phenomenon	1/2	Stating the factors	1/2 + 1/2	Law	1/2	(b) Sketch of change in		i. Flux	1	ii. Emf	1	iii. Force	1	<p>1 1 1</p>	<p>5</p>
(a) Identification of phenomenon	1/2																
Stating the factors	1/2 + 1/2																
Law	1/2																
(b) Sketch of change in																	
i. Flux	1																
ii. Emf	1																
iii. Force	1																



OR

Phasor diagram	1/2
Derivation of expression for current	1 1/2
Power dissipated	2
Reason for maximum power dissipation at resonance	1

Phasor diagram

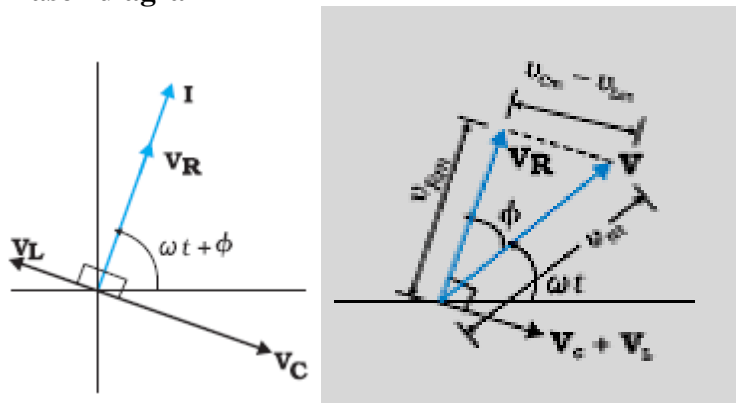

Using the phasor diagram, we get

$$v_m^2 = v_{Rm}^2 + (v_{Cm} - v_{Lm})^2$$

$$\text{Or } v_m^2 = i_m^2 [R^2 + (X_C - X_L)^2]$$

$$\therefore i_m = \frac{v_m}{\sqrt{R^2 + (X_C - X_L)^2}}$$

Also, $\tan \phi = \frac{v_C - v_L}{v_R} = \frac{X_C - X_L}{R}$

\therefore the expression, for current, is

$$i = i_m \sin(\omega t + \phi)$$

(Note: Award these two marks even if the student draws the phasor diagram / does the derivation of $i = i_m \sin(\omega t - \phi)$ for $X_C < X_L$)

Power dissipated:

The instantaneous power, p, supplied by the source, is

$$p = \vartheta i$$

$$= (\vartheta_m \sin \omega t)(i_m \sin(\omega t + \phi))$$

$$= \frac{\vartheta_m i_m}{2} [\cos \phi - \cos(2\omega t + \phi)]$$

The average power, over a cycle, is, therefore

$$P = \langle p \rangle = \frac{V_m i_m}{2} (\cos \phi)$$

$$= VI \cos \phi$$

At resonance, we have

1/2

1/2

1/2

1/2

1/2

1/2

1/2

1/2

(b) We have, as per Malus's law:

$$I = I_0 \cos^2 \theta$$

∴ If the intensity of light, incident on P_1 , is I_0 , we have

$$I_1 = \text{Intensity transmitted through } P_1 = \frac{I_0}{2}$$

$$I_2 = \text{Intensity transmitted through } P_2 = \left(\frac{I_0}{2}\right) \cos^2 60^\circ = \frac{I_0}{8}$$

For $\theta = 30^\circ$, we have

Angle between pass axis of P_2 and P_3

$$= (30^\circ + 30^\circ) = 60^\circ$$

$$\text{or } (30^\circ - 30^\circ) = 0^\circ$$

$$\therefore I_3 \text{ can be either } \frac{I_0}{32} \text{ or } \frac{I_0}{8}.$$

For $\theta = 60^\circ$, we have

Angle between pass axis of P_2 and P_3

$$= (30^\circ + 60^\circ) = 90^\circ$$

$$\text{or } (30^\circ - 60^\circ) = -30^\circ$$

$$\therefore I_3 \text{ can be either } 0 \text{ or } \frac{3I_0}{32}.$$

[Note: Award the last $(1 + \frac{1}{2})$ marks to the student even if he/she calculates I_3 for only the first (or second) values of the angle between the pass axis of P_2 and P_3 .]

OR

a) Expression for Path difference	2 ½
Conditions for constructive and destructive interference	½ + ½
b) Finding intensities at points where path difference is	
(i) $\lambda/6$	½
(ii) $\lambda/4$	½
(iii) $\lambda/3$	½

(a)

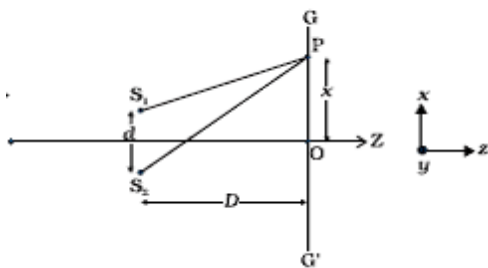

½

½

½

1

½

5

